

DUCT-M

Ventilatore assiale intubato motore "UNEL-MEC" Ducted axial fan - "IEC" Motor



APPLICAZIONI

I ventilatori della serie DUCT-M sono ideali per impieghi in cui necessitano grandi portate d'aria e pressioni relativamente modeste, in applicazioni con fissaggio a canalizzazioni. Ad esempio: impianti di ventilazione e condizionamento industriale in applicazioni minerarie, navali, torri evaporative, scambiatori di calore, raffreddamento di apparecchiature elettriche, frigoriferi ecc. La serie DUCT-M permette l'uso di ventilatori assiali in presenza di discrete pressioni utilizzando la versione multistadio che prevede due o più ventilatori abbinati in serie, controrotanti. Questa soluzione consente il recupero della componente rotativa dell'aria trasformandola in pressione, sviluppando fino a 2,7 volte la pressione di un singolo ventilatore con uguale geometria e velocità.

GAMMA

La serie è costituita da 13 grandezze con diametro girante da 310 a 1250 mm.

PECULIARITÀ

La serie DUCT-M è caratterizzata dall'estrema robustezza della costruzione essenzialmente dovuta alle flange ricavate direttamente dalla virola (e non riportate), e dallo spessore dei materiali utilizzati. Un'altra caratteristica è la varietà di versioni e di modelli di cui è composta la serie, il che permette la soluzione idonea a numerosi problemi di ventilazione. La girante prevede un robusto mozzo a morsa, in fusione d'alluminio per il fissaggio delle pale. Pale realizzate mediante stampaggio di diversi materiali aventi sempre l'obiettivo di sopportare elevati carichi di lavoro.

CONSTRUZIONE

- Convogliatore in lamiera d'acciaio protetto con verniciatura epossipoliestirica. Flange dimensionate a norma UNI ISO 6580 / EUROVENT 1-2.
- Girante ad alto rendimento con pale a profilo alare, ad angolo di calettamento variabile da fermo, in tecnopolimero oppure in fusione d'alluminio, mozzo in fusione d'alluminio. Equilibratura secondo norme UNI ISO 1940.
- Motore elettrico asincrono a corrente alternata, protezione IP 55, isolamento Cl F, servizio S1, forma B3, costruzione conforme alle specifiche norme IEC / EEC (UNEL-MEC).
- Esecuzione 4 (accoppiamento diretto con girante a sbalzo).

SPECIFICHE TECNICHE

DUCT-M standard

- Aria convogliata: pulita o leggermente polverosa, non abrasiva.
- Temperatura aria convogliata: -20°C / +50°C
- Tensione d'alimentazione: versione trifase (T) 400V- 3 Ph - 50Hz versione monofase (M) 230-1Ph - 50Hz
- Flusso d'aria da motore a girante, posizione A (FMG)

VERSIONI

DUCT Mm: convogliatore medio: gruppo motore/ girante quasi completamente incluso nella lunghezza della cassa

DUCT-Ml: convogliatore lungo.

Gruppo motore/girante completamente "incluso" nella lunghezza della cassa.

DUCT-Ms: convogliatore corto.

Motore sporgente dalla cassa ed accessibile.

ACCESSORI

- Boccaglio in aspirazione (IN).
- Silenzianti (SIL-DU).
- Rete antinfortunistica piana (FPG-DU) e conica (CPG-DU) (Necessaria nell'utilizzo a bocca libera).
- Portello d'ispezione.
- Giunto antivibrante (FC-DU).
- Supporti antivibranti (AV).
- Controflangia (CF-DU).
- Morsettiera esterna (OTB).
- Piedi di fissaggio (FF-DU).
- Interruttore di servizio (SW).

A RICHIESTA

- Prestazioni diverse da quelle rappresentate
- Versioni con girante avente pale in alluminio.
- Versioni con flusso dell'aria "effettivamente" reversibile (DUCT-REV).
- Versioni Atex (Duct Atex).
- Versioni multistadio (DUCT-CT).
- Versioni per fumi d'incendio (Duct-ht).
- Versioni con convogliatore in acciaio inossidabile o alluminio o lamiera zincata a caldo.
- Versioni con flusso d'aria da girante a motore, posizione B (FGM).

APPLICAZIONI

DUCT- M line is suitable when large air capacities with relatively low pressures are required in duct mounted applications. For instance: ventilation and conditioning in naval and mining applications, evaporative towers, heat exchangers, cooling of electric and refrigerating equipments, etc. With this line is possible to attain higher pressures using the multistage version consisting of two single stages fans mounted in series, with contra-rotating impellers. This solution allows the recovery of the air rotative component turning it in pressure, developing up to 2.7 times the pressure of a single fan having the same geometry and speed.

RANGE

This line consists of 13 sizes with impeller diameter from 310 up to 1250 mm.

ADVANTAGES

DUCT- M line is characterised by the extreme sturdiness of construction, thanks to the flanges directly bended on the casing, and the thickness of the materials. The variety of versions and models allows the solution of most of the problems of ventilation. Impeller consists of a strong hub, in die-cast aluminum alloy for the fixing of the blades. Available in different materials suitable for heavy duties.

CONSTRUCTION

- Casing in steel sheet protected with epoxy painting. Fixing flanges according to UNI-ISO 6580/EUROVENT 1-2 standards.
- Impeller with high efficiency airfoil blades in plastic material or in die-cast aluminum alloy. Hub in die-cast aluminum alloy. Balancing according to UNI ISO 1940. Variable pitch angle in still position.
- Asynchronous electric motor, protection IP 55, class F insulated, form B3, service S1 construction according to the IEC/IEC (UNEL-MEC) standard.
- Arrangement 4 (impeller directly coupled to motor shaft).

TECHNICAL SPECIFICATIONS

DUCT- M standard

- Conveyed air: clean, not abrasive.
- Temperature of conveyed air: -20°C/+50°C.
- Voltage: three phase version (T) 400V-3Ph. Single phase version (M) 230V-1Ph.
- Frequency: 50Hz.
- Air flow from motor to impeller, position A (FMG).

VERSIONS

DUCT-Mm: medium length casing: motor/impeller assembly almost completely enclosed within the length of the casing.

DUCT-Ml: long casing.

Impeller and motor are completely enclosed within the overall length of the casing.

DUCT-Ms: short casing.

Motor partially protrudes beyond the rear mounting flange.

ACCESSORIES

- Inlet nozzle (IN).
- Silencers (SIL-DU).
- Flat protection grid (FPG-DU) and conic (CPG-DU) (Necessary for use in free air)
- Inspection door.
- Flexible connection (FC-DU).
- Antivibration mounts (AV).
- Counter flange (CF-DU).
- Outer terminal box (OTB).
- Fixing feet (FF-DU).
- Service switch (SW).

ON REQUEST

- Performances differing from standard
- Versions with impeller with in die-cast aluminum blades
- Versions with true reversible airflow (DUCT-REV).
- Explosion proof versions (DUCT Atex).
- Multistage system versions (DUCT-CT).
- Smoke exhaust version (DUCT Ht)
- Versions with casing in stainless steel, aluminum, or hot dip galvanised steel.
- Versions with air flow from impeller to motor, position B (FGM).

2 poli/poles (3000 rpm) - monofase/single-phase (1Ph-230V 50Hz)

Modello Model	Portata - Flow rate (m ³ /h)	Pm (kW)	In max (A)	Mot. (H)	Lp dB(A)
312/A M	3.000	0,25	1,7	63	67
352/A M	4.600	0,55	4	71	74
402/A M	7.000	1,1	7,5	80	76

2 poli/poles (3000 rpm) - trifase/three-phases (3Ph-400V 50Hz)

Modello Model	Portata - Flow rate (m ³ /h)	Pm (kW)	In max (A)	Mot. (H)	Lp dB(A)
312/A T	3.000	0,25	0,7	63	67
352/A T	4.600	0,55	1,6	71	74
402/A T	7.000	1,1	2,6	80	76

4 poli/poles (1500 rpm) - mono fase/single-phase (1Ph-230V 50Hz)

Modello Model	Portata - Flow rate (m ³ /h)	Pm (kW)	In max (A)	Mot. (H)	Lp dB(A)
314/A M	2.400	0,12	1,1	63	50
354/A M	2.600	0,12	1,1	63	52
354/B M	3.200	0,12	1,1	63	54
404/A M	4.000	0,12	1,1	63	56
404/B M	5.000	0,18	1,6	63	59
454/A M	5.250	0,25	2,4	71	60
454/B M	6.800	0,37	3,1	71	65

4 poli/poles (1500 rpm) - trifase/three-phases (3Ph-400V 50Hz)

Modello Model	Portata - Flow rate (m ³ /h)	Pm (kW)	In max (A)	Mot. (H)	Lp dB(A)
314/A T	2.400	0,12	0,4	63	50
354/A T	2.600	0,12	0,4	63	52
354/B T	3.200	0,12	0,4	63	54
404/A T	4.000	0,12	0,4	63	56
404/B T	5.000	0,18	0,6	63	59
454/A T	5.250	0,25	0,8	63	60
454/B T	6.800	0,37	1,2	71	65
504/A T	7.500	0,37	1,2	71	61
504/B T	9.000	0,55	1,6	80	66
564/A T	10.000	0,55	1,6	80	66
564/B T	12.500	0,75	2	80	67
634/A T	13.000	0,75	2	80	70
634/B T	16.000	1,1	2,8	90S	72
634/C T	16.500	2,2	5	100	77
714/A T	16.500	1,5	3,5	90L	76
714/B T	20.000	2,2	5	100	78
714/C T	18.500	2,2	5	100	78
804/A T	24.000	3	6,5	100	78
804/B T	29.000	4	8,2	112	79
804/C T	35.000	5,5	11	132s	81
904/A T	38.000	5,5	11	132S	81
904/B T	43.000	7,5	15	132M	83
904/C T	47.000	7,5	15	132M	85
1004/A T	41.000	5,5	11	132S	83
1004/B T	50.000	7,5	15	132M	84
1004/C T	59.000	11	21	160L	86

6 poli/poles (1000 rpm) - trifase/three-phases (3Ph-400V 50Hz)

Modello Model	Portata - Flow rate (m ³ /h)	Pm (kW)	In max (A)	Mot. (H)	Lp dB(A)
506/A T	6.000	0,18	0,7	71	55
566/A T	7.900	0,25	1	71	58
636/A T	10.500	0,37	1,3	80	63
636/B T	12.700	0,75	2,2	90S	65
716/A T	15.000	0,75	2,2	90S	65
716/B T	17.000	1,1	3	90L	66
806/A T	16.000	0,75	2,2	90S	65
806/B T	19.000	1,1	3	90L	66
806/C T	22.500	1,5	4	100	69
906/A T	25.000	1,5	4	100	68
906/B T	29.000	2,2	5	112	70
906/C T	32.000	2,2	5	112	72
1006/A T	27.000	1,5	4	100	70
1006/B T	33.000	2,2	5	112	72
1006/C T	41.000	3	7	132S	74
1126/A T	36.000	3	7	132S	72
1126/B T	45.000	4	9	132M	73
1126/C T	54.000	5,5	12	132M	77
1256/A T	49.000	5,5	12	132M	75
1256/B T	61.000	7,5	15	160M	76
1256/C T	73.000	11	22	160L	80

8 poli/poles (750 rpm) - trifase/three-phases (3Ph-400V 50Hz)

Modello Model	Portata - Flow rate (m ³ /h)	Pm (kW)	In max (A)	Mot. (H)	Lp dB(A)
568/A T	6.000	0,12	0,7	71	52
638/A T	8.000	0,18	0,8	80	57
718/A T	11.000	0,37	1,5	90S	58
808/A T	10.000	0,37	1,5	90S	58
808/B T	13.000	0,37	1,5	90S	60
808/C T	16.000	0,55	2	90L	62
908/A T	17.000	0,75	2,3	100	61
908/B T	20.500	0,75	2,3	100	63
908/C T	24.500	1,1	3,4	100	65
1008/A T	20.500	0,75	2,3	100	64
1008/B T	25.000	1,1	3,4	100	65
1008/C T	31.000	1,5	4,2	112	67
1128/A T	27.000	1,5	4,2	112	66
1128/B T	34.000	2,2	5,5	132S	67
1128/C T	40.500	2,2	5,5	132S	70
1258/A T	34.500	2,2	5,5	132S	69
1258/B T	43.000	3	7,3	132M	70
1258/C T	52.000	4	9,3	160M	73

DUCT-M 310

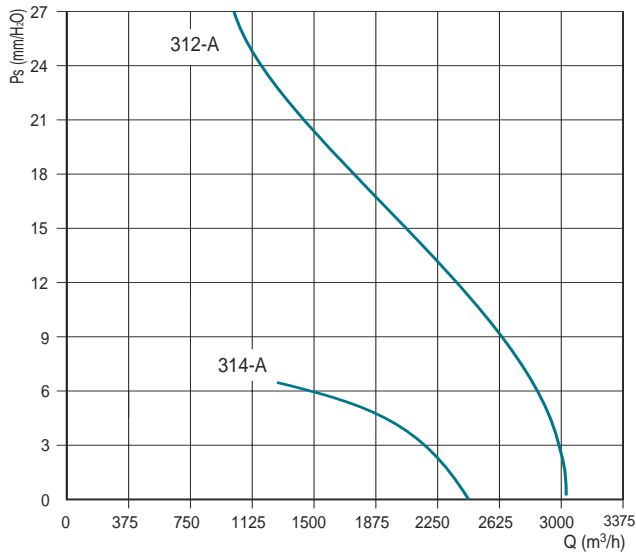

DUCT-M 350

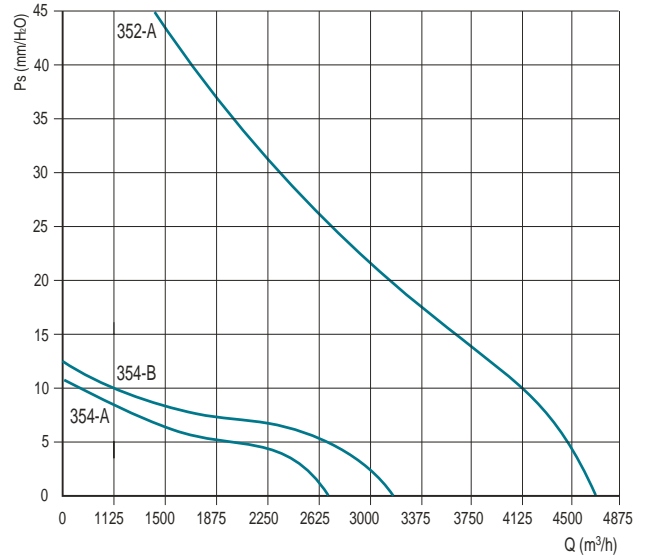

DUCT-M 400

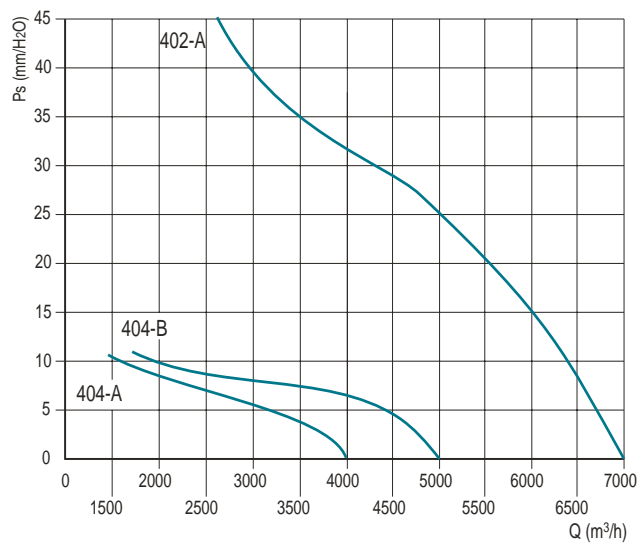

DUCT-M 450

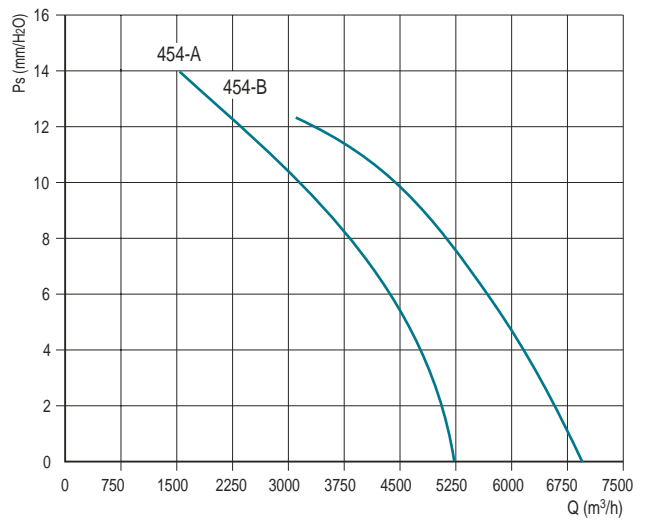

DUCT-M 500

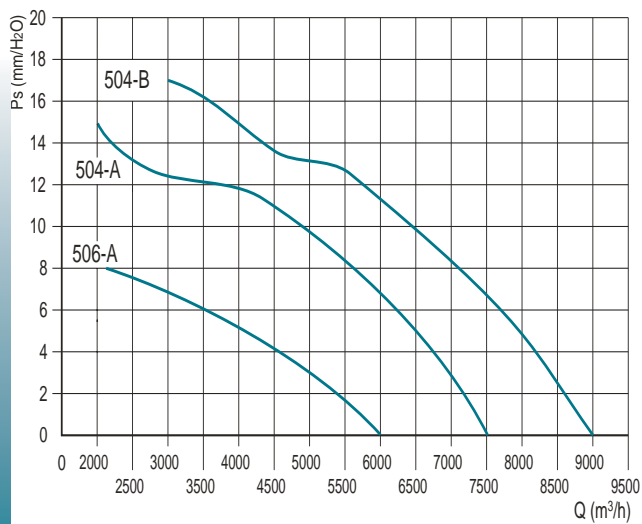

DUCT-M 560

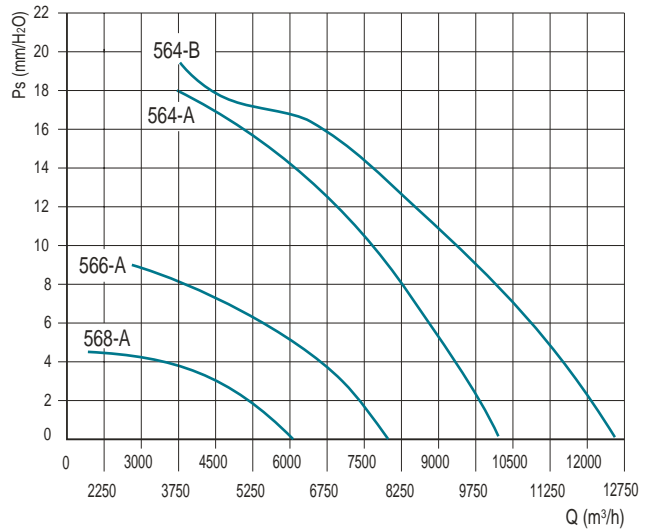

DUCT-M 630

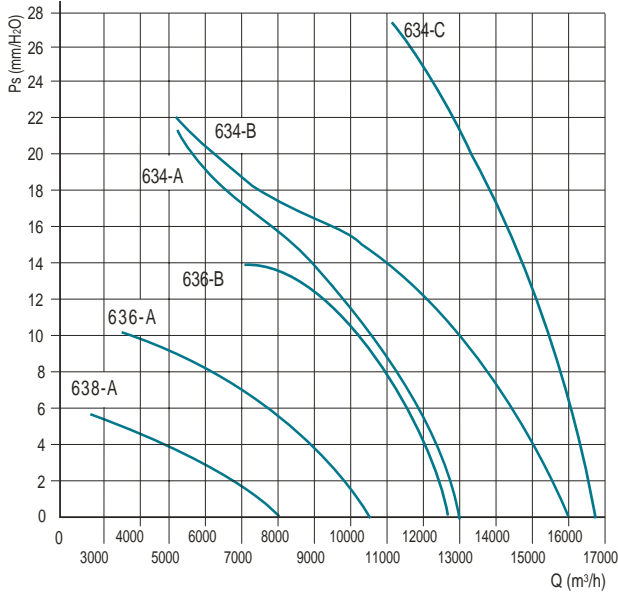

DUCT-M 710

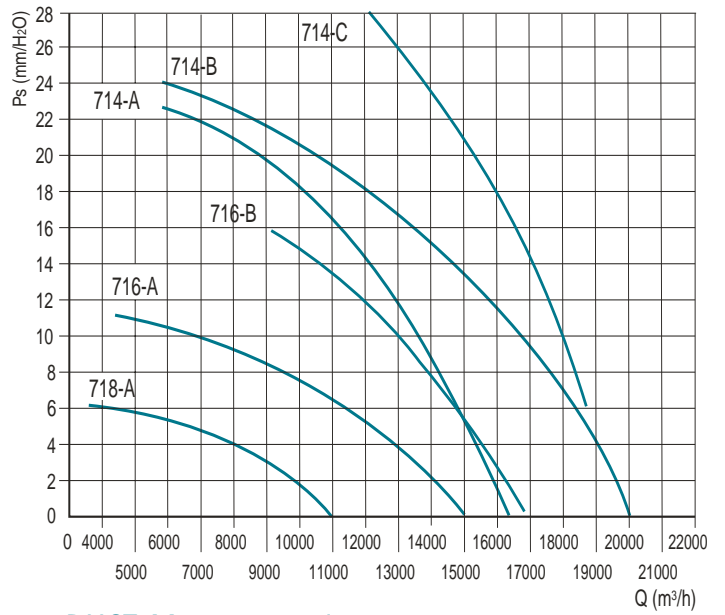

DUCT-M 800 - 4 poles

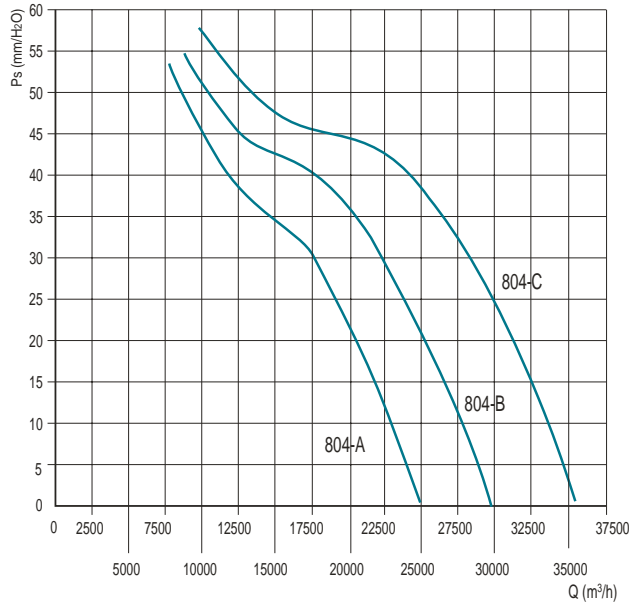

DUCT-M 800 - 6 poles

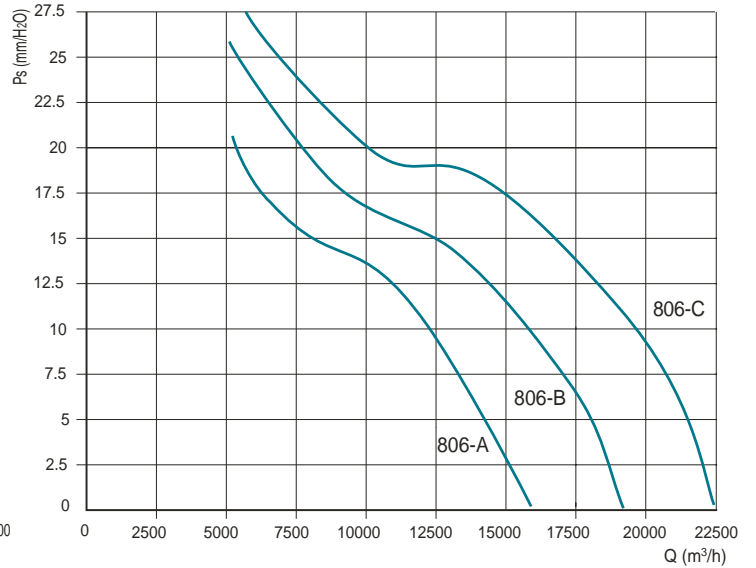

DUCT-M 800 - 8 poles

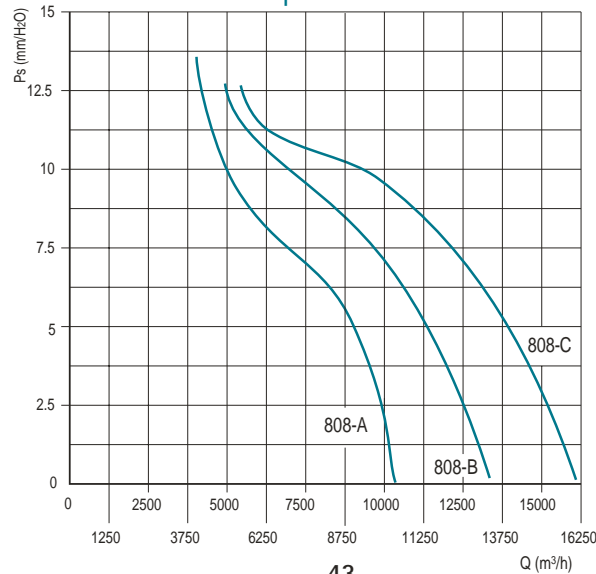

DUCT-M 900 - 4 poles

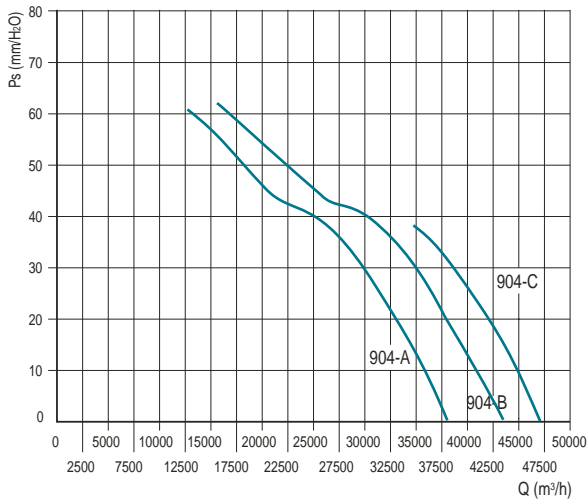

DUCT-M 900 - 6 poles

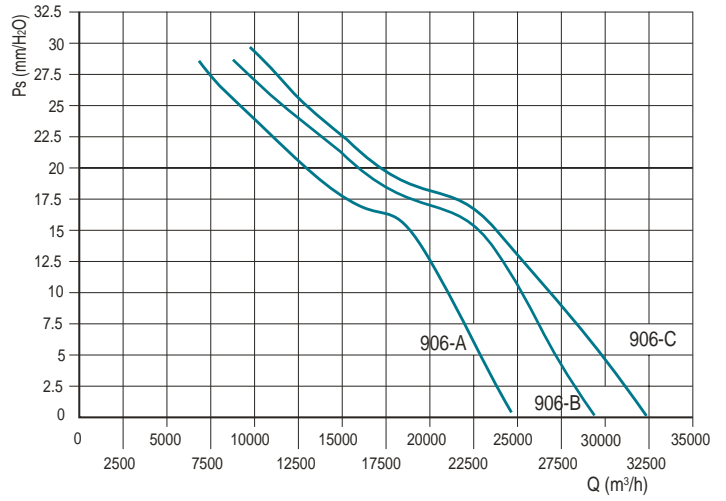

DUCT-M 900 - 8 poles

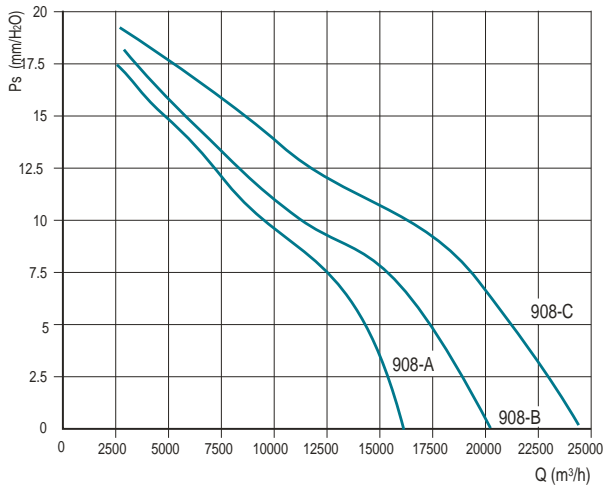

DUCT-M 1000 - 4 poles

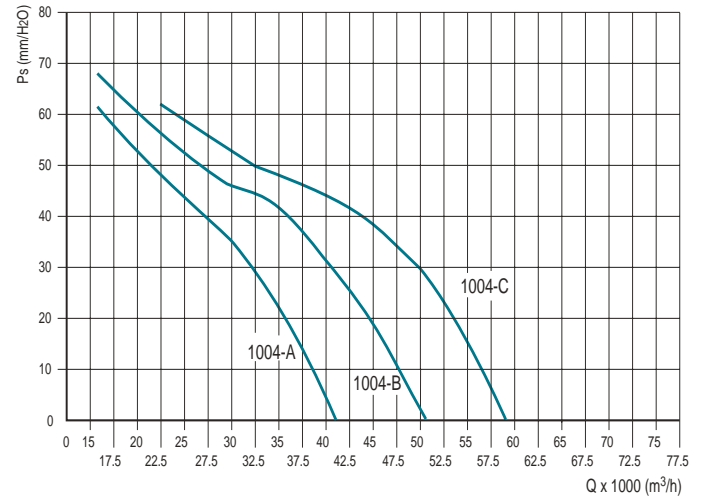

DUCT-M 1000 - 6 poles

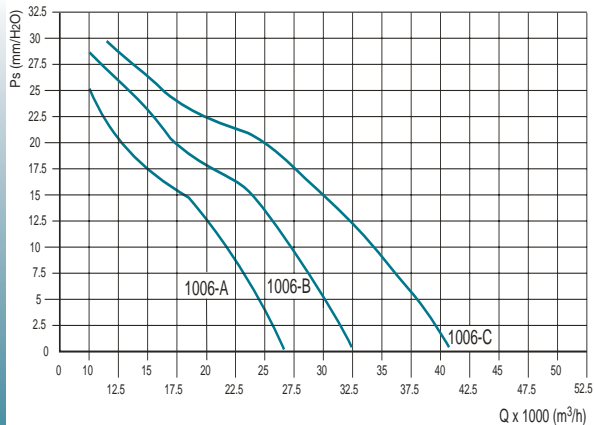

DUCT-M 1000 - 8 poles

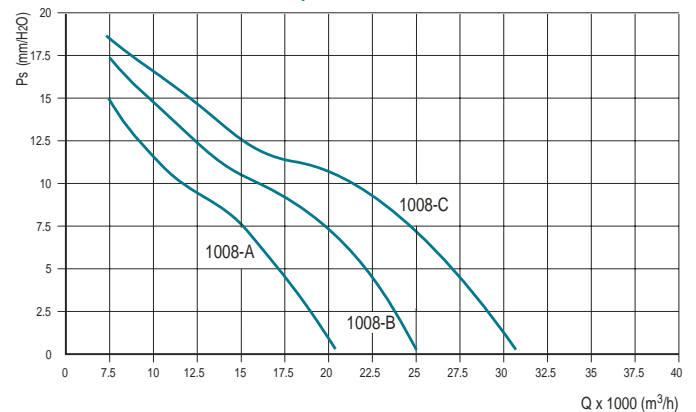

DUCT-M 1120 - 6 poles

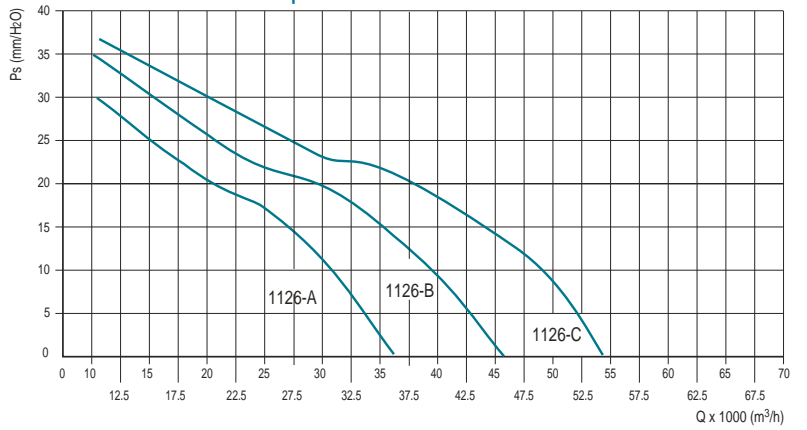

DUCT-M 1120 - 8 poles

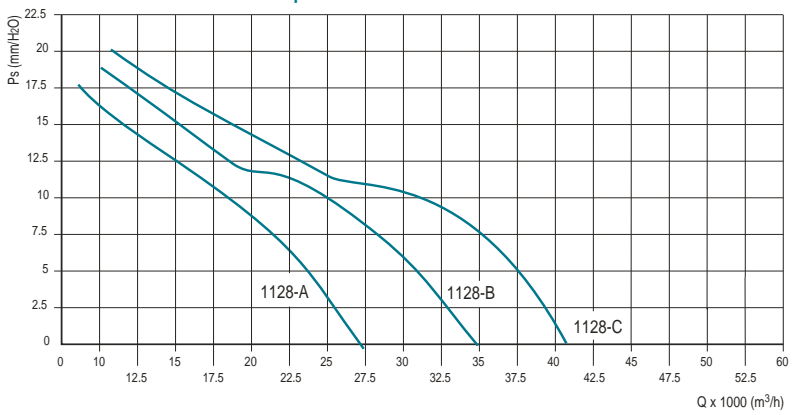

DUCT M 1250 - 6 poles

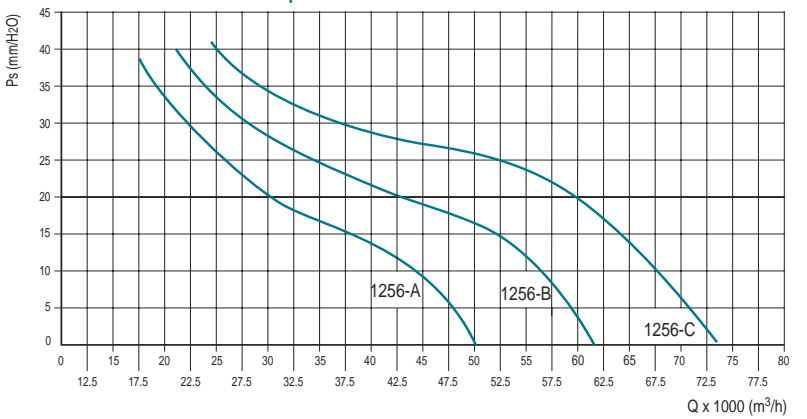

DUCT-M 1250 - 8 poles

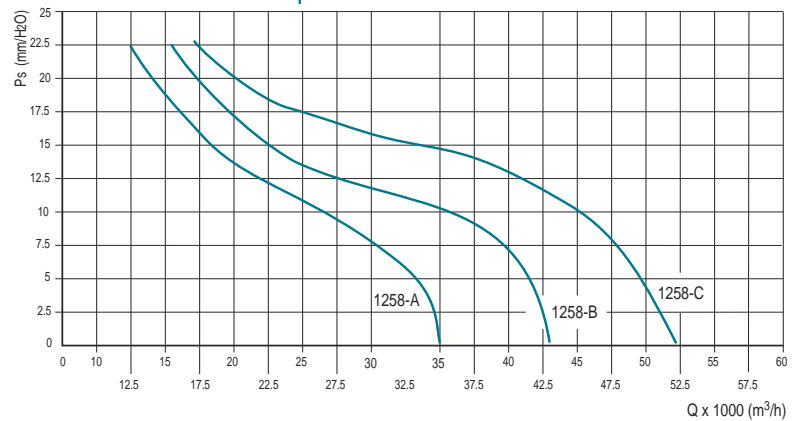

2 poli/poles

Hz

Model DUCT-M	63	125	250	500	1k	2k	4k	8k	Total
312/A - 0,25 kW	33	39	60	59	63	62	55	44	67
352/A - 0,55 kW	35	42	66	65	69	69	61	49	74
402/A - 1,1 kW	31	41	65	66	72	72	65	55	76

4 poli/poles

Hz

Model DUCT-M	63	125	250	500	1k	2k	4k	8k	Total
314/A - 0,12 kW	30	33	41	41	43	46	41	30	50
354/A - 0,12 kW	22	37	41	46	47	45	42	37	52
354/B - 0,12 kW	24	39	43	48	49	47	44	39	54
404/A - 0,12 kW	38	39	45	48	49	51	48	39	56
404/B - 0,18 kW	41	42	48	51	52	54	51	42	59
454/A - 0,25 kW	42	43	48	51	54	55	41	44	60
454/B - 0,37 kW	47	48	53	56	59	60	46	49	65
504/A - 0,37 kW	47	49	54	54	54	54	53	47	61
504/B - 0,55 kW	52	54	59	59	59	59	58	52	66
564/A - 0,55 Kw	32	51	61	59	59	59	57	49	66
564/B - 0,75 Kw	33	52	62	60	60	60	58	50	67
634/A - 0,75 Kw	35	50	60	61	64	67	61	53	70
634/B - 1,1 Kw	37	52	62	63	66	69	63	55	72
634/C - 2,2 Kw	46	56	70	70	71	69	66	61	77
714/A - 1,5 Kw	37	50	61	64	69	72	67	57	76
714/B - 2,2 Kw	39	52	63	66	71	74	69	59	78
714/C - 2,2 Kw	45	57	71	71	72	70	67	62	78
804/A - 3 kw	45	57	71	71	72	70	67	62	78
804/B - 4 Kw	48	58	72	72	73	71	68	63	79
804/C - 5,5 Kw	50	60	74	74	75	73	70	65	81
904/A - 5,5 Kw	50	60	74	74	75	73	70	65	81
904/B - 7,5 Kw	52	62	76	76	77	75	72	67	83
904/C - 7,5 Kw	55	65	79	79	80	78	75	70	85
1004/A - 5,5 Kw	52	62	76	76	77	75	72	67	83
1004/B - 7,5 Kw	53	63	77	77	79	77	73	69	84
1004/C - 11 Kw	55	65	79	79	80	78	75	70	86



6 poli/poles

Hz

Model DUCT-M	63	125	250	500	1k	2k	4k	8k	Total
506/A - 0,18 Kw	39	49	47	46	47	49	45	36	55
566/A - 0,25 Kw	24	43	53	51	50	50	49	41	58
636/A - 0,37 Kw	28	43	53	51	57	60	54	46	63
636/B - 0,75 Kw	35	50	54	59	60	58	58	50	65
716/A - 0,75 Kw	29	49	53	53	59	61	55	53	65
716/B - 1,1 Kw	36	51	55	60	61	59	56	51	66
806/A - 0,75 Kw	35	50	54	59	60	58	55	50	65
806/B - 1,1 Kw	36	51	55	60	61	59	56	51	66
806/C - 1,5 Kw	39	54	58	63	64	62	59	54	69
906/A - 1,5 Kw	38	43	57	62	63	61	58	53	68
906/B - 2,2 Kw	40	55	59	64	65	63	60	55	70
906/C - 2,2 Kw	42	57	61	66	67	65	62	57	72
1006/A - 1,5 Kw	40	55	59	64	65	63	60	55	70
1006/B - 2,2 Kw	42	57	61	66	67	65	62	57	72
1006/C - 3 Kw	44	59	63	68	69	67	64	59	74
1126/A - 3 Kw	42	57	61	66	67	65	62	57	72
1126/B - 4 Kw	43	58	62	67	68	66	63	58	73
1126/C - 5,5 Kw	47	61	65	71	71	65	67	61	77
1256/A - 5,5 Kw	45	60	64	69	70	68	65	60	75
1256/B - 7,5 Kw	46	61	65	70	71	69	66	61	76
1256/C - 11 Kw	50	64	68	74	74	72	70	64	80

8 poli /poles

Hz

Model DUCT-M	63	125	250	500	1k	2k	4k	8k	Total
568/A - 0,12 Kw	18	37	47	45	45	45	43	35	52
638/A - 0,18 Kw	22	37	47	48	51	54	48	40	57
718/A - 0,37 Kw	34	43	51	48	52	53	45	32	58
808/A - 0,37 Kw	28	43	47	52	53	51	48	43	58
808/B - 0,37 Kw	30	45	49	54	55	53	50	45	60
808/C - 0,55 Kw	32	47	51	56	57	55	52	47	62
908/A - 0,75 Kw	31	46	50	55	56	54	51	46	61
908/B - 0,75 Kw	33	48	52	57	58	46	53	48	63
908/C - 1,1 Kw	35	50	54	59	60	58	55	50	65
1008/A - 0,75 Kw	34	49	53	58	59	57	54	49	64
1008/B - 1,1 Kw	35	50	54	59	60	58	55	50	65
1008/C - 1,5 Kw	37	52	56	61	62	60	57	52	67
1128/A - 1,5 Kw	36	51	55	60	61	59	56	51	66
1128/B - 2,2 Kw	37	52	56	61	62	60	57	52	67
1128/C - 2,2 Kw	40	55	59	64	65	63	60	55	70
1258/A - 2,2 Kw	39	54	58	63	64	62	59	54	69
1258/B - 3 Kw	40	55	59	64	65	63	60	55	70
1258/C - 4 Kw	43	58	62	67	68	66	63	58	73



Attenzione: il livello di pressione sonora è riferito ad una misurazione onnidirezionale in campo libero a 3 m dal ventilatore con aspirazione e mandata canalizzate.

Attention: sound pressure level is measured in free field at 3 m from the fan, in any direction, with ducted inlet and outlet.

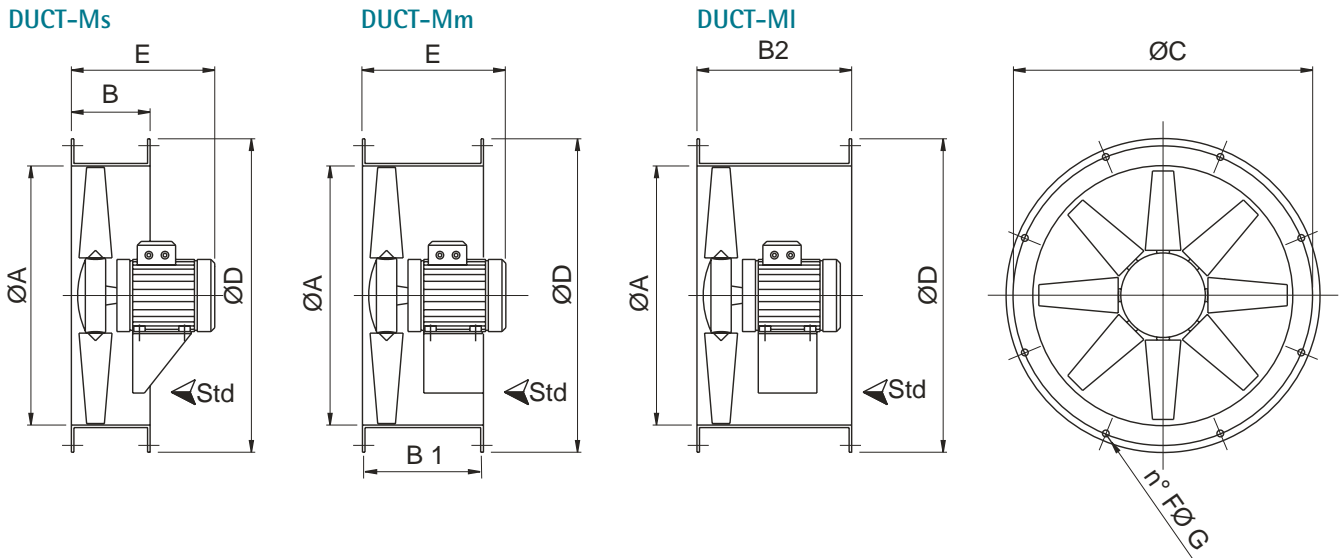

Model	A	B	B1	B2	C	D	* E	F	G	*kg (Ms)	*kg (Mm)	*kg (MI)
31	310	260	260	400	355	390	250/380	8	10	13/18	13/18	13/20
35	360	260	260	400	395	430	250/380	8	10	14/19	14/19	14/24
40	410	260	260	400	450	490	300/390	8	12	16/27	16/27	19/30
45	460	260	260	450	500	540	350/430	8	12	23/33	23/33	26/36
50	510	260	260	450	560	595	350/440	12	12	25/40	25/40	29/44
56	570	260	260	450	620	655	350/440	12	12	28/45	28/45	34/51
63	640	260	350	500	690	725	400/490	12	12	34/56	37/59	41/63
71	710	260	350	600	770	805	400/560	16	12	41/92	44/95	53/104
80	810	350	450	600	860	900	450/590	16	12	50/120	54/124	60/134
90	910	350	450	700	970	1010	450/690	16	16	80/197	87/204	105/222
100	1010	350	560	800	1070	1110	550/750	16	16	92/235	107/250	123/266
112	1130	350	560	800	1190	1230	550/750	20	16	120/289	136/295	157/317
125	1260	350	560	800	1320	1360	550/780	20	16	150/310	169/329	192/352

Dimensioni in mm/Dimensions in mm

(*) Indicativo/Indicative

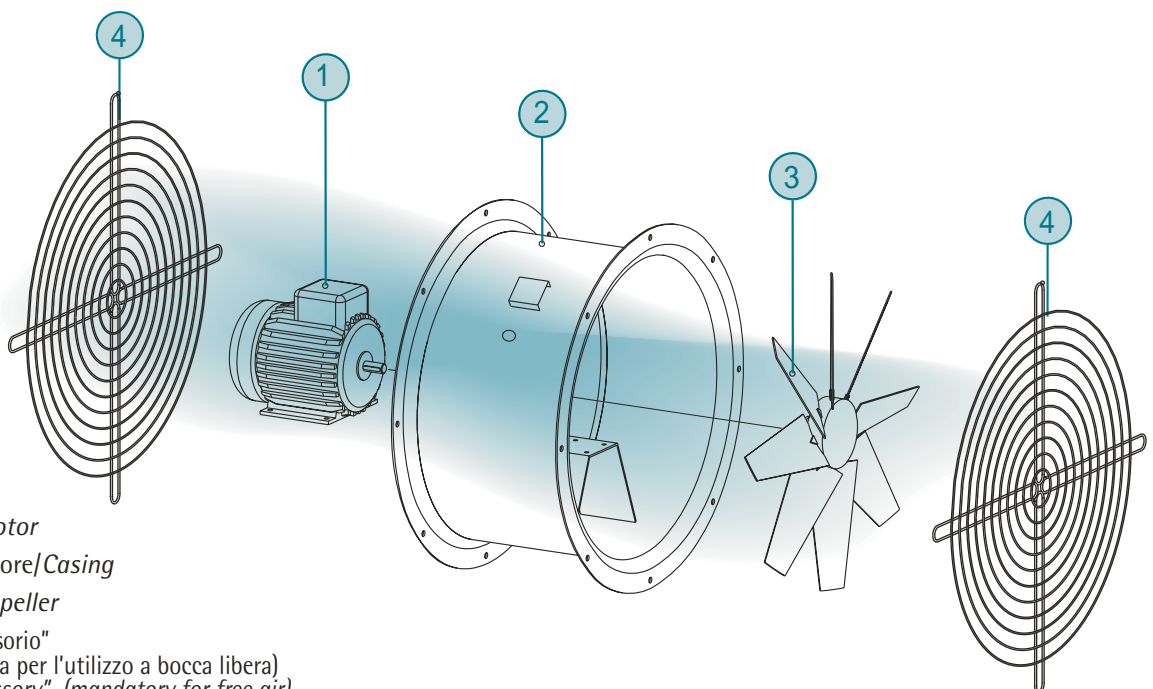

- 1 - Motore/Motor
- 2 - Convogliatore/Casing
- 3 - Girante/Impeller
- 4 - Rete "accessorio"
(obbligatoria per l'utilizzo a bocca libera)
Grid "accessory" (mandatory for free air)

SIL SILP

Silenziatori circolari

Circular silencers

SIL-DU

SILP-DU

SILENZIATORI CIRCOLARI SIL-DU/SILP-DU

I silenziatori cilindrici SIL-DU sono disponibili in due versioni, senza ogiva (SIL) e con ogiva (SILP), la presenza dell'ogiva permette una maggiore attenuazione della rumorosità ma genera una perdita di carico nell'impianto (vedi diagramma). Entrambe le versioni possono essere fissate alla flangia del DUCT corrispondente sia in aspirazione sia in mandata. Esistono 3 tipologie con lunghezza di 1, 1,5 e 2 volte il diametro (A). Questi silenziatori sono costruiti completamente in lamiera zincata, la parte interna e l'ogiva in lamiera forata e il materiale fonoassorbente in lana minerale. La temperatura d'esercizio è compresa fra -40 e +150°C e la massima pressione 1000 mm/H2O.

CIRCULAR SILENCERS SIL-DU/SILP-DU

The cylindrical silencers CCs are available in two versions, without pod (SIL) and with pod (SILP), the presence of the pod allows a greater attenuation of the noise but produces a load loss in the plant. Both the versions can be fixed to the corresponding flange of the DUCT in inlet and outlet. It is possible to provide 3 versions with length of 1, 1.5 and 2 times diameter (A). These silencers are manufactured completely in galvanized steel. The internal part and the pod in punctured sheet and mineral wool. The working temperature is included from -40 and +150°C and the maximum pressure corresponds to 1000 mm/H2O.

SIL senza ogiva/without pod																					
Model	G = 1xØ							G = 1,5xØ							G = 2xØ						
	125	250	500	1k	2k	4k	8k	125	250	500	1k	2k	4k	8k	125	250	500	1k	2k	4k	8k
31	1	3	8	14	9	8	7	2	5	12	19	13	11	8	6	6	16	26	17	13	9
35	0	3	9	14	10	8	6	0	5	12	21	13	11	9	2	6	15	25	16	12	10
40	0	4	10	13	8	8	5	1	5	14	19	12	10	8	2	7	18	24	15	12	9
45	1	4	12	12	9	6	6	1	6	17	17	13	9	8	1	7	21	21	15	10	8
50	0	4	13	11	9	6	5	1	6	18	17	12	9	7	2	8	23	21	14	11	8
56	0	4	14	11	8	5	4	2	7	20	15	11	8	5	1	9	24	19	14	10	7
63	1	5	14	10	9	5	5	2	7	20	14	12	8	6	2	9	25	17	14	10	7
71	1	5	12	9	7	5	5	2	7	18	11	9	6	7	4	9	24	14	11	8	8
80	3	7	9	8	6	5	4	5	10	13	12	9	7	7	6	13	22	14	10	9	7
90	3	7	13	8	6	5	4	5	11	16	11	7	7	5	6	14	23	13	9	7	6
100	3	8	12	8	4	4	4	5	12	17	10	6	6	5	6	16	23	12	7	7	6
112	3	8	13	7	5	4	3	5	12	18	8	6	5	4	6	15	23	10	7	6	6
125	3	9	13	7	4	4	3	6	12	17	8	5	5	4	8	17	22	10	6	6	5

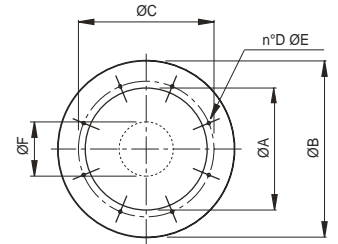

SILP con ogiva/with pod																					
Model	G = 1xØ							G = 1,5xØ							G = 2xØ						
	125	250	500	1k	2k	4k	8k	125	250	500	1k	2k	4k	8k	125	250	500	1k	2k	4k	8k
31	1	4	9	16	17	13	10	4	5	13	23	26	18	12	6	7	17	32	33	22	17
35	0	4	11	22	21	15	12	1	7	15	33	32	22	17	2	8	19	40	39	27	20
40	1	4	11	20	18	14	11	2	6	15	31	27	19	14	2	9	20	37	35	23	16
45	1	6	14	21	19	13	9	2	7	19	31	28	18	12	3	10	23	39	36	21	15
50	2	5	13	20	16	11	8	3	7	19	29	24	14	10	3	10	24	38	32	18	12
56	1	6	15	21	17	11	8	3	9	22	32	27	15	11	2	12	27	41	35	18	12
63	1	6	15	19	16	10	8	2	9	22	29	23	14	10	3	11	27	37	29	15	12
71	2	7	15	20	18	12	10	3	11	22	31	25	13	11	5	14	29	41	32	18	15
80	3	9	12	17	15	9	8	6	13	18	26	22	12	11	6	16	29	35	26	15	12
90	4	8	15	16	11	8	7	5	12	20	24	16	10	9	7	17	30	34	20	12	11
100	8	14	20	24	21	14	10	10	22	30	37	29	16	12	13	28	39	47	38	19	13
112	6	13	20	21	14	8	7	10	19	29	33	20	11	10	14	26	36	42	24	13	11
125	7	12	18	19	10	6	6	10	18	26	29	14	9	7	13	25	35	37	17	11	9

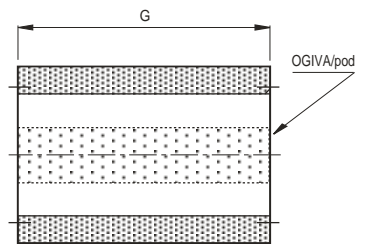

Perdite di carico dei silenziatori SILP-DU

Silencers SILP-DU pressure Loss

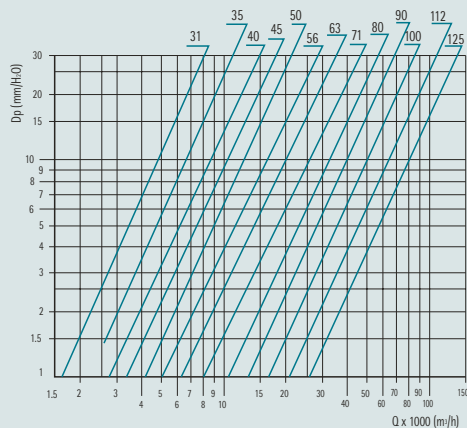

N.B. Versione senza ogiva SIL perdita di carico irrilevante
Note : Silencer without pod SIL loss charge insignificant

Silenziatori circolari

Circular silencers

Dimensioni

Dimensions

MODEL	ØA	ØB	ØC	D	ØE	ØF (SILP)	G 1xØ	G 1,5xØ	G 2xØ
31	315	455	355	8	M8	150	315	470	630
35	355	495	395	8	M8	150	350	525	700
40	400	540	450	8	M10	195	400	600	800
45	450	610	500	8	M10	195	450	675	900
50	500	660	560	12	M10	250	500	750	1000
56	560	720	620	12	M10	250	560	840	1120
63	630	790	690	12	M10	300	630	945	1260
71	710	870	770	16	M10	380	710	1065	1420
80	800	1000	860	16	M10	380	800	1200	1600
90	900	1100	970	16	M12	380	900	1350	1800
100	1000	1200	1070	16	M12	655	1000	1500	2000
112	1120	1320	1190	20	M12	655	1120	1680	2240
125	1250	1450	1320	20	M12	655	1250	1875	2500

Dimensioni in mm/Dimensions in mm

BOCCAGLIO (IN-DU)

Permette un maggior rendimento del ventilatore nel caso di bocche non canalizzate. Costruito in lamiera di acciaio, con flangia realizzata a norme UNI ISO6580 – EUROVENT1/2, per fissaggio alla cassa e una flangia raggiata. Protetto contro gli agenti atmosferici.

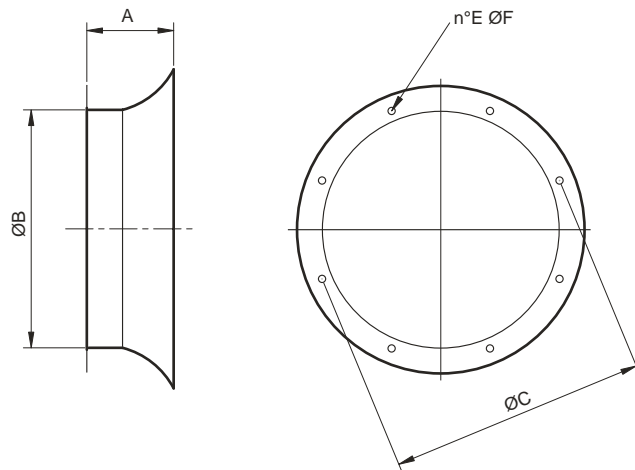

INLET CONE (IN-DU)

It improves the fan efficiency in case of free inlet or outlet. Manufactured in steel sheet, one flange is designed to be fixed with the fan flange according to UNI ISO6580 – EUROVENT1/2 standards, and the other flange is round shaped. Protected against the atmospheric agents.

Model	A	ØB	ØC	E	ØF	kg
IN-DU 31	135	315	355	8	10	2
IN-DU 35	135	350	395	8	10	3
IN-DU 40	150	400	450	8	12	4
IN-DU 45	160	450	500	8	12	5
IN-DU 50	160	500	560	12	12	6
IN-DU 56	160	560	620	12	12	6.5
IN-DU 63	160	630	690	12	12	7
IN-DU 71	180	710	770	16	12	11
IN-DU 80	200	800	860	16	12	13
IN-DU 90	250	900	970	16	16	18
IN-DU 100	250	1000	1070	16	16	20
IN-DU 112	250	1120	1190	20	16	23
IN-DU 125	250	1250	1320	20	16	25

Dimensione in mm/Dimensions in mm

RETE DI PROTEZIONE (FPG-DU)

Salvaguardano dal contatto accidentale con le parti in movimento del ventilatore. Realizzate in filo d'acciaio a norme UNI9219-EUROVENT1/3 e protette contro gli agenti atmosferici (Necessaria nell'utilizzo a bocca libera).

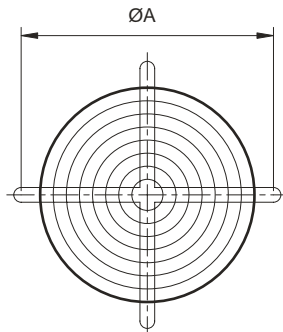

FPG - DU - Versione piana per DUCT-M
Safety grid for DUCT-Mm

PROTECTION GUARD (FPG-DU)

They preserve from the casual contact with the rotating parts of the fan. Manufactured in steel rod according to UNI9219-EUROVENT1/3 standards and protected against the atmospheric agents (Necessary for use in free air)

Model	ØA	kg
FPG-DU 31	355	0.6
FPG-DU 35	395	0.6
FPG-DU 40	450	0.8
FPG-DU 45	500	1
FPG-DU 50	560	1.3
FPG-DU 56	620	1.6
FPG-DU 63	690	1.9
FPG-DU 71	770	2.2
FPG-DU 80	860	3
FPG-DU 90	970	3.4
FPG-DU 100	1070	3.5
FPG-DU 112	1190	4
FPG-DU 125	1320	4.5

Dimensione in mm/Dimensions in mm

PIEDI DI FISSAGGIO (FF-DU)

Consentono l'ancoraggio del ventilatore. Realizzate in lamiera d'acciaio e protette contro gli agenti atmosferici.

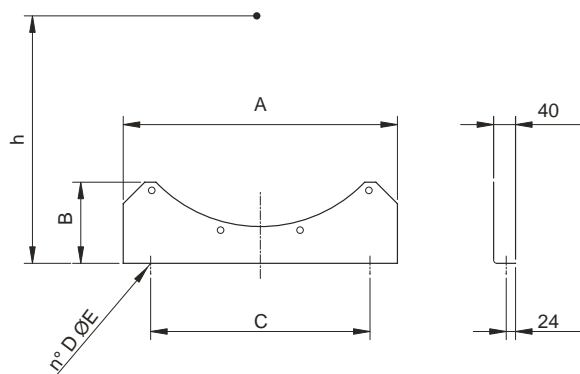

FIXING FEET (FF-DU)

They allow the fan fixing. Manufactured in steel sheet and protected against the atmospheric agents.

Model	A	B	C	D	ØE	h	kg
FF-DU 31	350	100	250	2	10	235	1
FF-DU 35	350	100	250	2	10	260	1
FF-DU 40	350	100	250	2	10	285	1
FF-DU 45	350	100	250	2	10	310	1
FF-DU 50	500	200	200	3	12	380	1.8
FF-DU 56	560	215	230	3	12	410	2
FF-DU 63	630	230	240	3	12	450	2.2
FF-DU 71	700	200	275	3	12	490	2.5
FF-DU 80	800	215	330	3	12	540	3
FF-DU 90	900	230	370	3	12	600	4
FF-DU 100	900	230	370	3	12	650	4
FF-DU 112	1120	326	460	3	12	710	10
FF-DU 125	1250	330	525	3	12	770	10

Dimensione in mm/Dimensions in mm

CONTROFLANGIA (CF-DU)
COUNTER FLANGE (CF-DU)

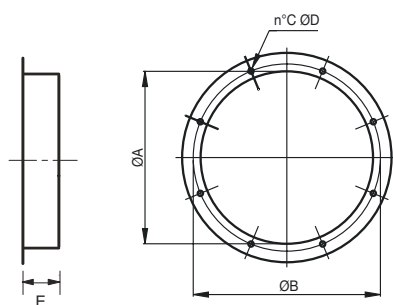

Model	ØA	ØB	C	ØD	E	kg
CF-DU 31	315	355	8	10	80	1.2
CF-DU 35	350	395	8	10	80	1.5
CF-DU 40	400	450	8	12	80	1.7
CF-DU 45	450	500	8	12	80	1.9
CF-DU 50	500	560	12	12	80	2.1
CF-DU 56	560	620	12	12	80	2.4
CF-DU 63	630	690	12	13	80	2.7
CF-DU 71	710	770	16	12	80	3.3
CF-DU 80	800	860	16	12	80	3.7
CF-DU 90	900	970	16	16	100	4.7
CF-DU 100	1000	1070	16	16	100	5.2
CF-DU 112	1120	1190	20	16	100	6.5
CF-DU 125	1250	1320	20	16	100	8

Dimensione in mm/Dimensions in mm

SUPPORTI ANTIVIBRANTI (AV)

Sono montati sotto ai piedi di sostegno per impedire la trasmissione di vibrazioni e rumori delle strutture. Sono in metallo-gomma speciale. Sono disponibili altri modelli e tipologie di AV in funzione delle applicazioni. Idonee solo per sollecitazioni di compressione.

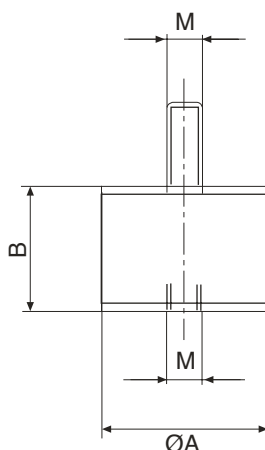

AV MOUNTS (AV)

They are fitted under the support brackets to avoid the transmission of vibrations and rumors of the structures. Made in special metal-rubber. Other models and types of AV mounts are available upon request according to the different applications. Suitable for compression strains only.

Model	Carico x 1 supporto Load for 1 support	A	B	M
AV 20	10÷20 kg	20	15	6
AV 30	21÷50 kg	30	20	8
AV 40	51÷65 kg	40	30	8
AV 50	66÷130 kg	50	30	10

Dimensione in mm/Dimensions in mm

GIUNTO ANTIVIBRANTE (FC-DU)

Impedisce la propagazione delle vibrazioni sulla canalizzazione. Temperature d'utilizzo -30°C + 80°C. Parti in lamiera protette contro gli agenti atmosferici. Per temperature diverse sono previste costruzioni speciali.

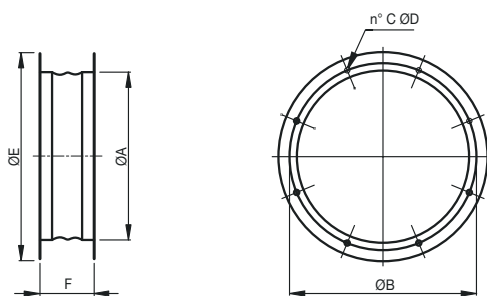

FLEX CONNECTION (FC-DU)

Designed to prevent the propagation of the vibrations along the duct. Working temperature -30°C + 80°C. Components in steel sheet protected against the atmospheric agents. For different temperatures are foreseen special constructions.

Model	A	B	C	D	E	F
FC-DU 31	315	355	8	10	395	200
FC-DU 35	350	395	8	10	466	200
FC-DU 40	400	450	8	12	496	200
FC-DU 45	450	500	8	12	546	200
FC-DU 50	500	560	12	12	598	200
FC-DU 56	560	620	12	12	658	200
FC-DU 63	630	690	12	12	730	200
FC-DU 71	710	770	16	12	810	200
FC-DU 80	800	860	16	12	910	200
FC-DU 90	900	970	16	16	1030	220
FC-DU 100	1000	1070	16	16	1130	220
FC-DU 112	1120	1190	20	16	1250	220
FC-DU 125	1250	1320	20	16	1380	220

Dimensione in mm/Dimensions in mm